

mody

ELECTRIC SUBMERSIBLE SEWAGE PUMP

MS 480 SERIES

SUBMERSIBLE SEWAGE PUMPS
FOR
STATIONARY WET PIT
INSTALLATION
(P TYPE)
AND
MOBILE WET PIT INSTALLATION
(S TYPE)

Model MS 481

4" (100mm) Flange or Hose
10 HP (7.5kW)
(Med. Volume - High Head)

Model MS 484

4" (100mm) Flange or Hose
10 HP (7.5kW)
(Med. Volume - Med. Head)

Model MS 482

6" (150mm) Flange or Hose
10 HP (7.5kW)
(High Volume - Med. Head)



PORTABLE INSTALLATION

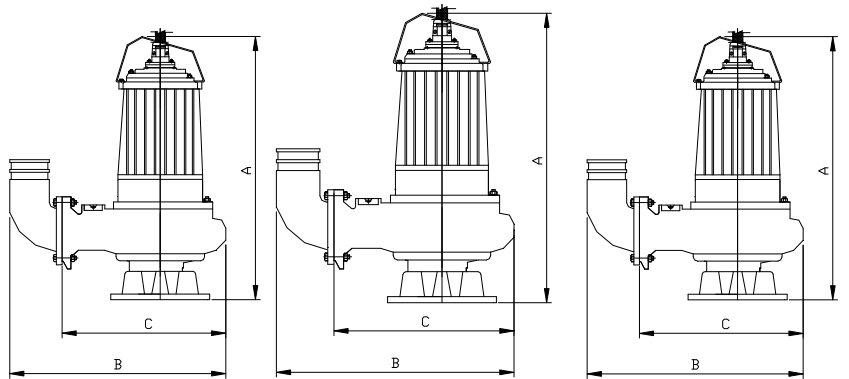

MS 481			MS 482			MS 484		
A	B	C	A	B	C	A	B	C
840	665	530	880	755	535	840	665	530
(33.0")	(26.1")	(20.8")	(34.6")	(29.7")	(21.0")	(33.0")	(26.1")	(20.8")

STATIONARY (SEMI PERMANENT) WET PIT INSTALLATION

	A	B	C	D	E	F	G	H	I	J	K	L	MØ	N	□	P	S	R
MS481	780	85	70	713	274	165	69	400	258	250	740	90	100	570	262	670	23	200
MS482	780	85	70	725	339	195	109	450	367	280	750	115	150	570	262	670	23	250
MS484	780	85	70	713	274	165	69	400	258	250	740	90	100	570	262	670	23	250

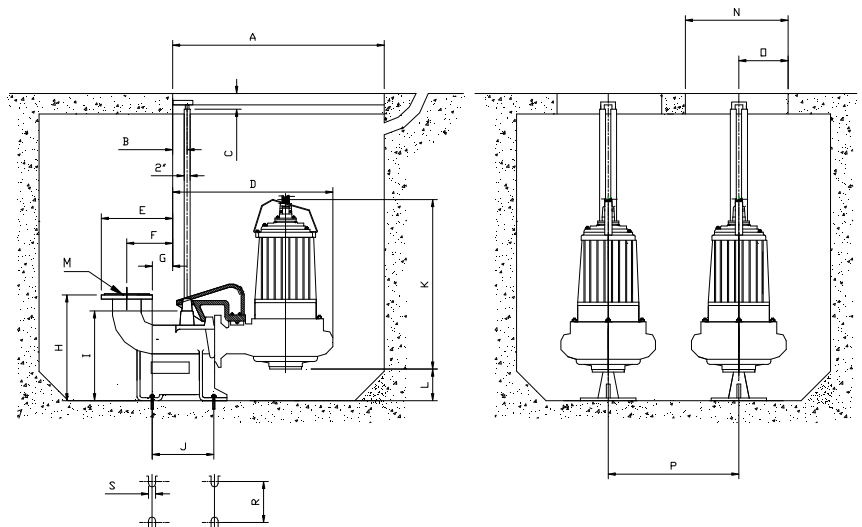

mody
Pumps

Mody Pumps® Inc.
2166 Zeus Court, Bakersfield, CA 93308. USA
Tel.: (661) 392-7600 • Fax: (661) 392-7601
<http://www.modypump.com>
E-mail: sales@modypump.com

mody

ELECTRIC SUBMERSIBLE SEWAGE PUMP

MS-480 SERIES 10HP (7.5kW)

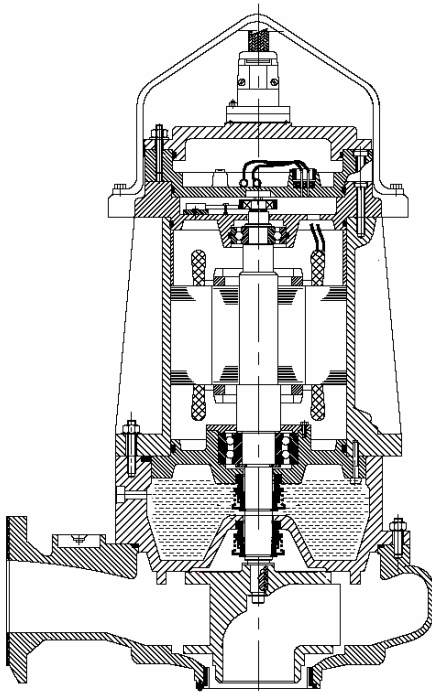

PERFORMANCE CURVES

MODEL: MS-481/MS-484/MS-482

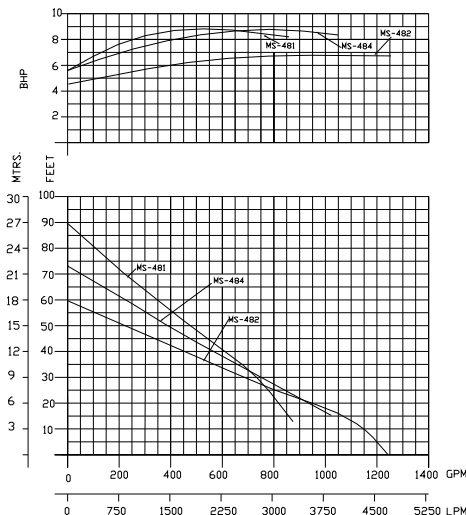

MS-480 SERIES

MATERIALS OF CONSTRUCTION AND ENGINEERING DATA

MODEL	MS 481	MS 484	MS 482
HP/kW	10/7.5	10/7.5	10/7.5
RPM 60Hz/50Hz	1750/1450	1750/1450	1750/1450
Max. Amps (FLA @ 460v/400v)	14/16	14/16	14/16
Solids Handling: inches/mm	3"/75 (80)	3"/75 (80)	4"/100
Weight - P Type (approx.) Lbs./Kg	495/225	495/225	528/240
Weight - S Type (approx.) Lbs./Kg	407/185	413/188	440/200
Impeller Type	Channel	Channel	Channel
Max. Temperature of Pumped Fluid:	104°F/40°C	104°F/40°C	104°F/40°C
Max. Starts/Stop Per Hour:	15	15	15
Max. Submergence:	33'/10m	33'/10m	33'/10m

MOTOR

4-pole induction **continuous rated** motor with squirrel cage rotor. Bi-metallic switches (thermals) embedded in stator winding to protect against overheating. Stator insulation class 'H' (180°C)

POWER SUPPLY

3 phase, 50/60 Hz, AC Supply. Available in any voltage frequency combination. (208/220/230/380/415/460/575/1000V)

BALL BEARINGS

The rotor shaft is carried in two ball bearings. Double row contact lower bearing is capable of carrying high thrust and radial loads. Upper bearing is a deep groove single row oversized bearing. The bearings are enclosed with high temperature grease containing special Anti-corrosion additive.

POWER CABLE

Waterproof/oil proof, rubber-insulated, neoprene-sheathed copper conductor flexible cable, 50ft. (15m) length standard. Type SOOW in North America, EPR in the Middle East and HO7RN in the EU. (4 core std., 7 core optional)

SHAFT SEALS

Compact Tandem Tungsten Carbide/Tungsten Carbide Upper & Lower Mechanical seals minimize shaft overhang and deflection maximizing mean time between service intervals. Moisture sensor available to detect progressive seal wear.

HYDRAULICS

Single Channel Impellers, Hydrodynamically balanced with improved flow pattern contribute to a virtually clog-free pump.

COOLING

Integral cast cooling fins on motor casing with large surface area ensure efficient heat dissipation and low temperature rise. Shrink fitted stators and short shaft overhang facilitate cooling.

MATERIALS OF CONSTRUCTION

Casing: Cast Iron ASTM A48 Class 30 (FG 220)
 Impeller: Cast Iron ASTM A48 Class 30 (FG 220)
 Shaft: 431 Stainless Steel
 Hardware: 304 Stainless Steel
 "O" Rings: Nitrile Rubber
 Mech. Seals: TC/TC (Upper & Lower)

SURFACE TREATMENT

Primer with Epoxy and subsequently coated with black chloric paint for maximum corrosion resistance. pH range 6 - 11.